

2P View

◆ SPECIFICATIONS

- Current rating: 1.5A AC, DC
- Voltage rating: 50V AC, DC
- Temperature range: -25°C ~ +85°C
- Insulation resistance: 100MΩ Min.
- Withstanding voltage: 500V AC/ minute.
- Contact resistance: 20mΩ Max.

Material: LCP UL94V-0
Suitable: E1201 series Crimp Terminal

E1201H00-NPX - XX-XX
① ② ③④ ⑤ ⑥

- ① Series No.
- ② H90 : Side Contact
H00 : Up Contact
- ③ No. of Circuits
- ④ X : Product color(A--Y)
Blank : Natural type
- ⑤ HF : Halogen Free
Blank : ROHS
- ⑥ NK : No Mark
Blank : Mark

PIN.	Dimension		
	A	B	C
2P	1.20	2.60	/
3P	2.40	3.80	1.20
4P	3.60	5.00	2.40
5P	4.80	6.20	3.60
6P	6.00	7.40	4.80
7P	7.20	8.60	6.00

④				GENERAL TOLERANCE	UNIT: mm	DATE	TITLE:
③				.X ± 0.30	X° ± 1°	DRAWN: 张自豪	JST 1.20 HSG
②				.XX ± 0.20	.X° ±	CHECKED:	
①				.XXX ± 0.10	.XX° ±	APPROVED: 张彬彬	2015.05.13
LTR	NAME	DATE	VERSION RECORD				

VER.	SCALE:	N/A
A1	SHEET:	1/1

东莞市宏欣蓝电子有限公司		
PROJECTION	PART NO.	E1201H00-NPX-XX-XX
	DRAWING NO.	E1201H

1 2 3 4 5 6 7 8 9

A

A

B

B

C

C

D

D

E

E

F

F

1 2 3 4 5 6 7 8 9

◆ SPECIFICATIONS

- Current rating: 1.5A AC, DC
- Voltage rating: 50V AC, DC
- Temperature range: -25°C ~ +85°C
- Insulation resistance: 100MΩ Min.
- Withstanding voltage: 500V AC/ minute.
- Contact resistance: 20mΩ Max.

Applicable Wires:

AWG#30~#36

Insulation O.D. : 0.75mm MAX

Material: Phosphor Bronze

Finish: Gold-flash over Nickel

Suitable: E1201&E1202 series Crimp Housing

Note: E1201TOP-XX-XX

空码: Mark
NK: NO Mark

Finish

5A--Gold-flash	5B--2u"	5C--3u"
5D--4u"	5E--5u"	5F--10u"
5G--15u"	5H--30u"	5I--50u"
0A--Gold-flash	0B--2u"	0C--3u"
0D--4u"	0E--5u"	0F--10u"
0G--15u"	0H--30u"	0I--50u"
2E--Tin-plated		

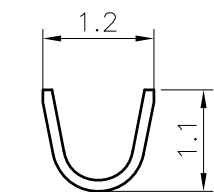
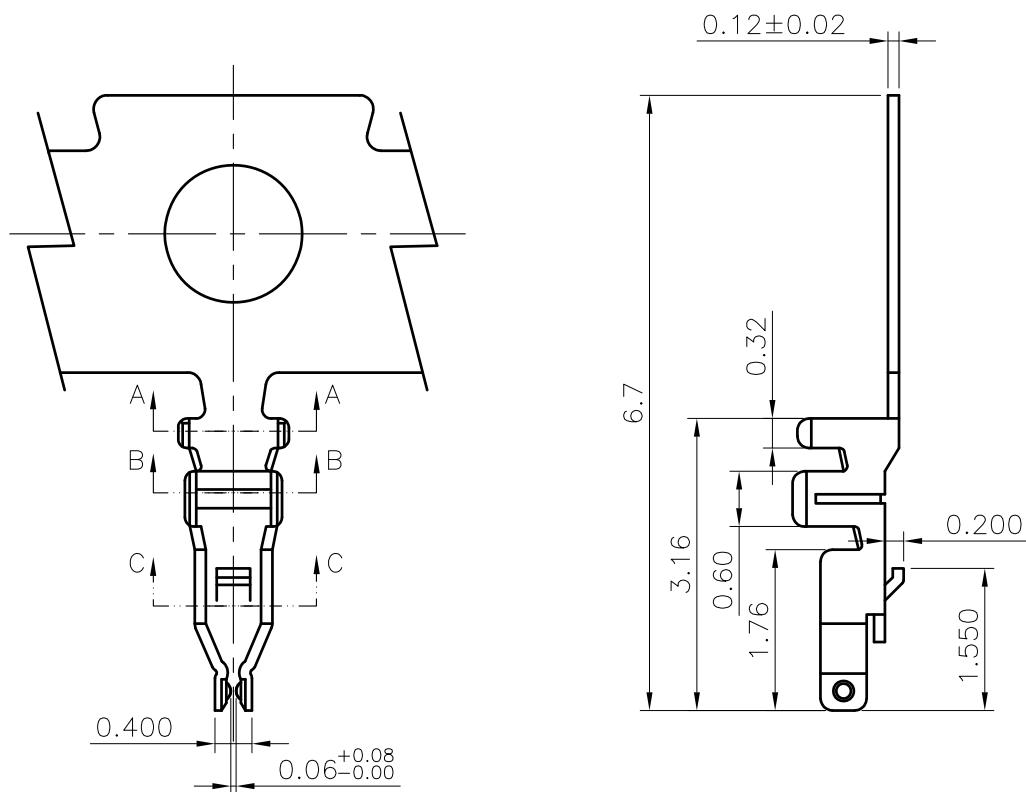

SECTION A-A

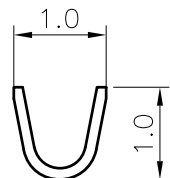

SECTION B-B

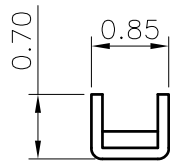

SECTION C-C

④				GENERAL TOLERANCE	UNIT: mm	DATE	TITLE: 1.20mm Crimp Style Terminal			东莞市宏欣蓝电子有限公司			
③				.X ± 0.30	X° ± 1°	DRAWN: 张自豪	2015.3.3	VER. SCALE: 12.5:1			PROJECT	PART NO.	E1201T0P-XX-XX
②				.XX ± 0.20	.X° ±	CHECKED:		A	SHEET:	1/1	DRAWING NO. E1201T		
①				.XXX ± 0.10	.XX° ±	APPROVED: 张彬彬	2015.3.3						
LTR	NAME	DATE	VERSION RECORD										

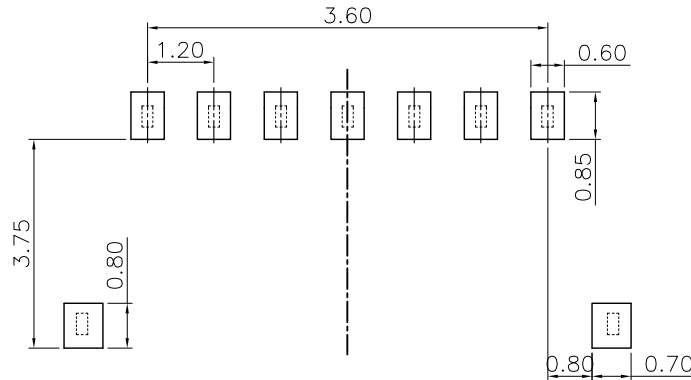
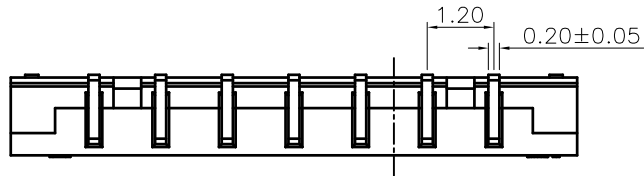

Recommended P.C.Board Layout

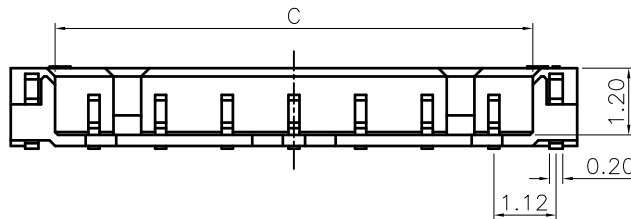
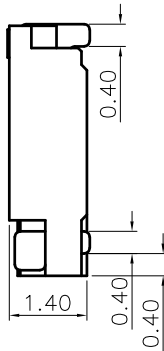
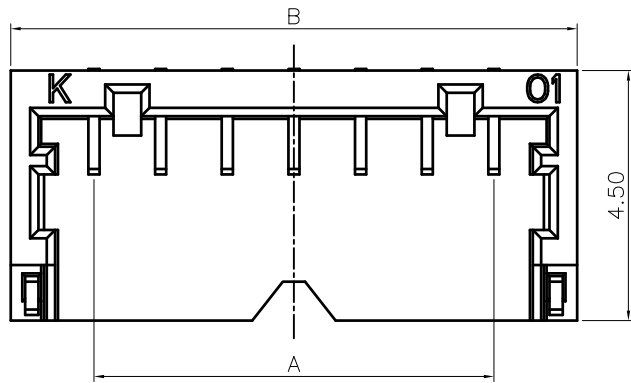

◆ SPECIFICATIONS

- Current rating: 1.5A AC, DC
- Voltage rating: 50V AC, DC
- Temperature range: -25°C ~ +85°C
- Insulation resistance: 100MΩ Min.
- Withstanding voltage: 500V AC/ minute.
- Contact resistance: 20mΩ Max.

Material:

Insulator: PA9T UL 94V-0 Black
 Contact: Phosphor bronze
 Fitting Nail: Brass

Plating:

Contact: Gold Flash plated
 Fitting Nail: Tin plated

Circuits: 2~7

Suitable: E1201 series Housing

Ordering code:

E1201W90-NP-S X X X XX
 ①②③④

- ① N=Halogen Free R=RoHS
- ② Material: 9=Nylon 9T L=LCP
- ③ Color: B=Black E=Beige
- ④ Plating code: T1=Tin plated
G1=Gold-flash

PIN.	Dimension		
	A	B	C
2P	1.20	4.30	2.64
3P	2.40	5.50	3.84
4P	3.60	6.70	5.04
5P	4.80	7.90	6.24
6P	6.00	9.10	7.44
7P	7.20	10.30	8.64

④			
③			
②			
①	王钰徽	2015.4.29	按实物修改B号尺寸,系列DIM尺寸加0.10
LTR	NAME	DATE	VERISION RECORD

GENERAL TOLERANCE		UNIT: mm	DATE
.X ± 0.30	X° ± 1°	DRAWN: 王钰徽	2015.07.07
.XX ± 0.20	.X° ±	CHECKED:	
.XXX ± 0.10	.XX° ±	APPROVED: 周志龙	2015.07.07

TITLE:		
JST 1.20mm SMT Wafer		
VER.	SCALE:	N/A
A	SHEET:	1/1

东莞市宏欣蓝电子有限公司

PROJECT	PART NO.	E1201W90-NP-SXXXXX
DRAWING NO.		E1201W90