

Specifications:

Rated Voltage : 250V AC/DC

Rated Current : 3A AC,DC

Contact Resistance: 10mΩ(Max.)

Withstand Voltage : 800V AC/minute

Insulation Resistance : 1000MΩ(MIN.)

Temperature Range : -25°C~+85°C

Material: Nylon 66,UL94V-0

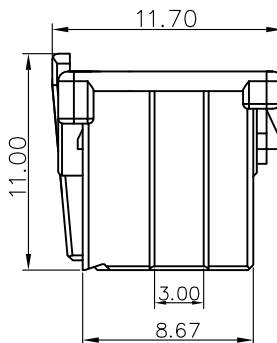
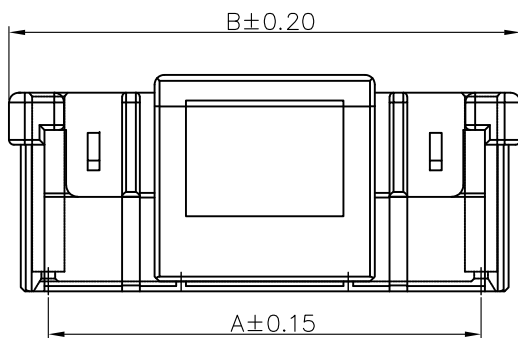

E2009H00-2xNPX-L-XX-XX
① ② ③ ④ ⑤ ⑥ ⑦

- ① Series No.
- ② H90 : Side Contact
H00 : Up Contact
- ③ No. of Circuits
- ④ X : Product color(A--Y)
A : Black type
- ⑤ L : Lock TYPE
- ⑥ HF: Halogen Free
Blank: Rohs
- ⑦ NK : No Mark
Blank : Mark

PART NO.	Dimension mm		
	A	B	C
2x4P	6.00	10.00	4.80
2x5P	8.00	12.00	4.80
2x6P	10.00	14.00	4.80
2x7P	12.00	16.00	4.80
2x8P	14.00	18.00	4.80
2x9P	16.00	20.00	4.80
2x10P	18.00	22.00	11.20
2x11P	20.00	24.00	11.20
2x12P	22.00	26.00	11.20
2x13P	24.00	28.00	11.20
2x14P	26.00	30.00	11.20
2x15P	28.00	32.00	11.20
2x16P	30.00	34.00	15.20
2x17P	32.00	36.00	15.20
2x18P	34.00	38.00	15.20
2x19P	36.00	40.00	15.20
2x20P	38.00	42.00	15.20
2x21P	40.00	44.00	15.20

				GENERAL TOLERANCE		UNIT: mm		DATE		TITLE:	
				.X ± 0.30	X° ± 1°	DRAWN: 张自豪		2021.10.24		JST PND2.00mm Housing	
				.XX ± 0.20	.X° ±	CHECKED:				VER. SCALE: N/A	
				.XXX ± 0.10	.XX° ±	APPROVED:				A0 SHEET: 1/3	
LTR	NAME	DATE	VERSION RECORD								

东莞市宏欣蓝电子有限公司

PROJECT PART NO. E2009H00-2xNPX-L-XX-XX

DRAWING NO. E2009H00

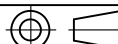

1

2

3

4

5

6

7

8

9

A

A

B

B

C

C

D

D

E

E

F

F

1

2

3

4

5

6

7

8

9

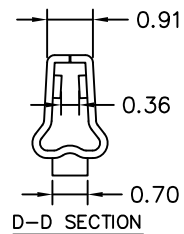
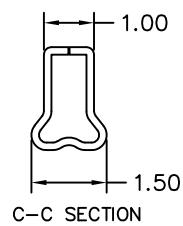
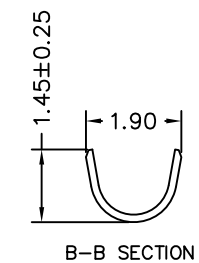
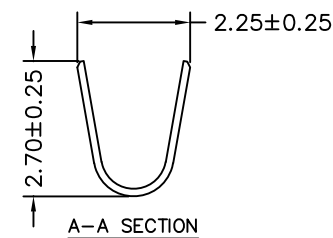
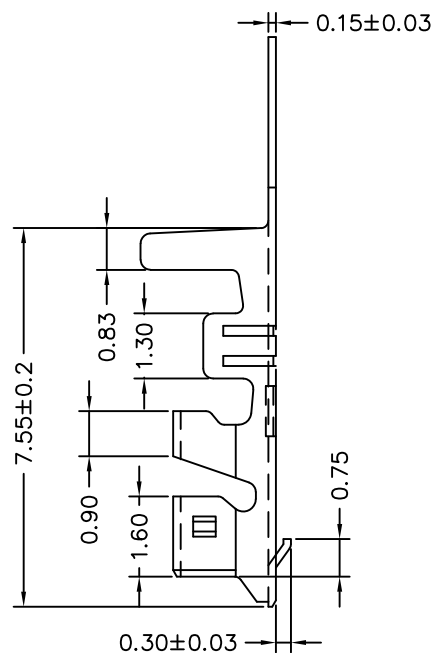
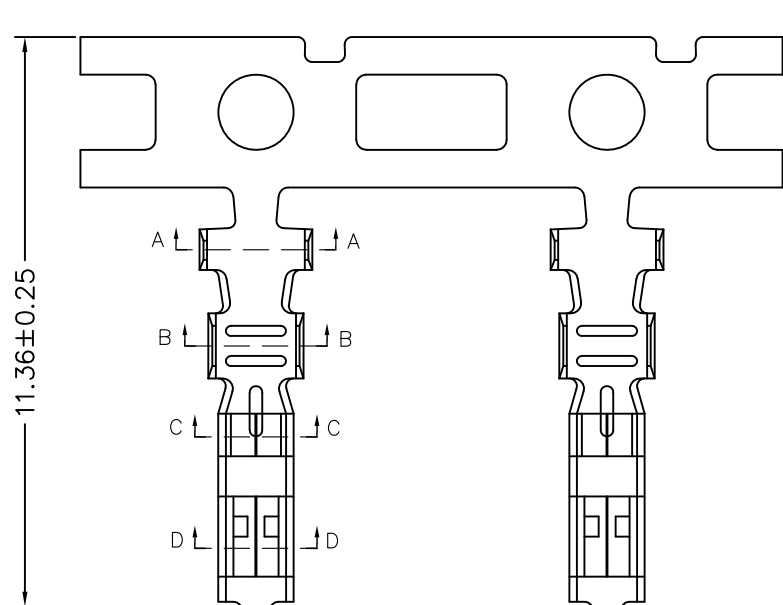

Specifications & Ordering Information:

Part No	Wire Range	Insulation O.D.	Material	Finish	Qty/reel
E2009TOP-2E-NK	AWG#22~#28	1.50mm(max)	Phosphor Bronze	Tin-Plated	8,000PCS

LTR	NAME	DATE	VERSION RECORD	GENERAL TOLERANCE	UNIT: mm	DATE	TITLE:	东莞市宏欣蓝电子有限公司		
				.X ± 0.30	X° ± 1°	DRAWN: 张自豪	2021.11.05	JST PND2.00mm Terminal		
				.XX ± 0.20	.X° ±	CHECKED:		PROJECT	PART NO.	E2009TOP-2E-NK
				.XXX ± 0.10	.XX° ±	APPROVED:		VER. A0	SCALE: 1/1	N/A
								DRAWING NO.	E2009T	

Specifications:
 Rated Voltage : 250V AC/DC
 Rated Current : 3A AC,DC
 Contact Resistance: 10mΩ(Max.)
 Withstand Voltage : 800V AC/minute
 Insulation Resistance : 1000MΩ(MIN.)
 Temperature Range : -25°C~+85°C
 Material: Nylon 66,UL94V-0

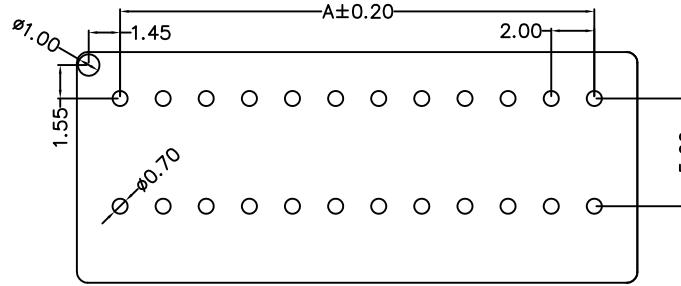
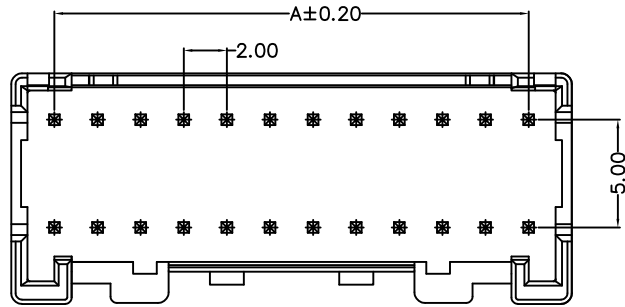

P.C.B LAYOUT

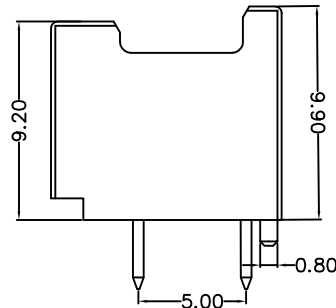
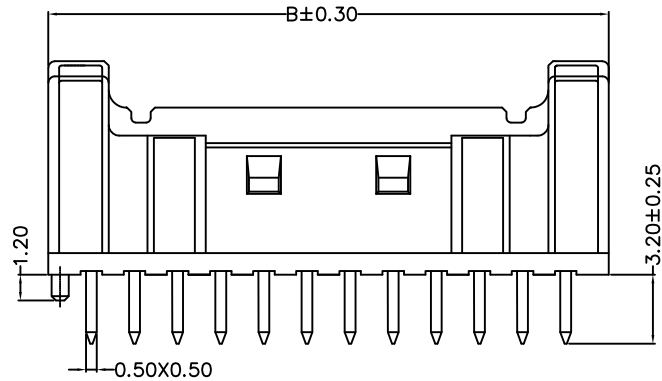

E2009W00-2xNPX-L-XX-XX
 ① ② ③ ④ ⑤ ⑥ ⑦

- ① Series No.
- ② W90 : Side Contact
W00 : Up Contact
- ③ No. of Circuits
- ④ X : Product color(A--Y)
A : Black type
- ⑤ L : Lock TYPE
- ⑥ HF: Halogen Free
Blank: Rohs
- ⑦ NK : No Mark
Blank : Mark

PART NO.	Dimension mm	
	A	B
2x4P	6.00	10.00
2x5P	8.00	12.00
2x6P	10.00	14.00
2x7P	12.00	16.00
2x8P	14.00	18.00
2x9P	16.00	20.00
2x10P	18.00	22.00
2x11P	20.00	24.00
2x12P	22.00	26.00
2x13P	24.00	28.00
2x14P	26.00	30.00
2x15P	28.00	32.00
2x16P	30.00	34.00
2x17P	32.00	36.00
2x18P	34.00	38.00
2x19P	36.00	40.00
2x20P	38.00	42.00
2x21P	40.00	44.00

				GENERAL TOLERANCE		UNIT: mm		DATE		TITLE:		东莞市宏欣蓝电子有限公司		
				.X ± 0.30	X° ± 1°	DRAWN: 张自豪		2021.11.05		JST PND2.00mm Wafer				
				.XX ± 0.20	.X° ±	CHECKED:				VER. SCALE: N/A		PROJECT	PART NO.	E2009W00-2xNPX-L-XX-XX
				.XXX ± 0.10	.XX° ±	APPROVED:				A0 SHEET: 1/2		DRAWING NO.		E2009W00
LTR	NAME	DATE	VERSION RECORD											

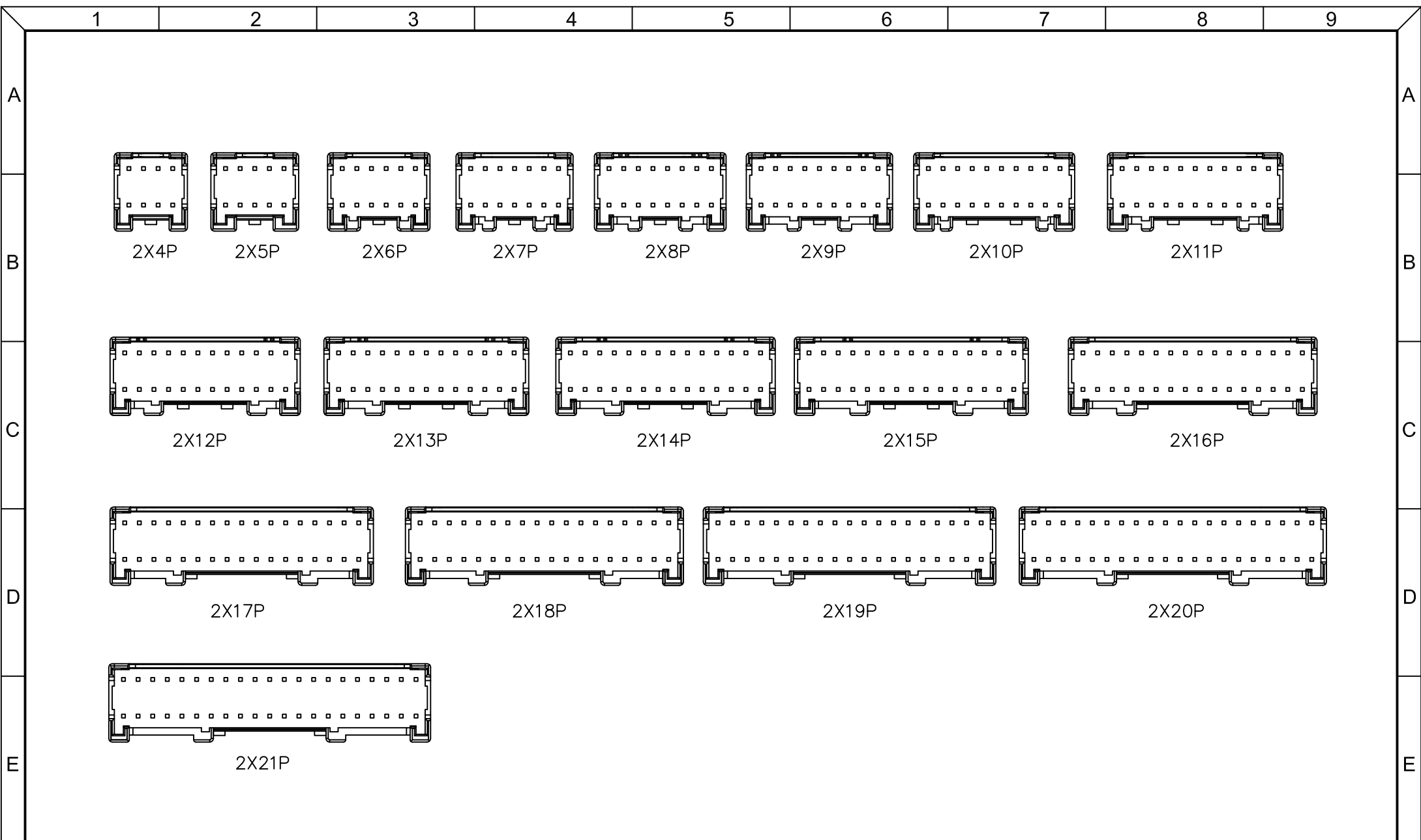

				GENERAL TOLERANCE		UNIT: mm		DATE		TITLE:		
				.X ± 0.30		X° ± 1°		DRAWN: 张自豪 2021.11.05		JST PND2.00mm Wafer		
				.XX ± 0.20		.X° ±		CHECKED:		PROJECT		
				.XXX ± 0.10		.XX° ±		APPROVED:		PART NO. E2009W00-2xNPX-L-XX-XX		
LTR	NAME	DATE	VERSION RECORD						VER. A0		SCALE: SHEET: N/A 2/2	
										DRAWING NO. E2009W00		

东莞市宏欣蓝电子有限公司

