

Specifications:  
 Rated Voltage : 250V AC/DC  
 Rated Current : 2.5A AC,DC  
 Withstand Voltage : 1000V AC/minute  
 Contact Resistance : 20mΩ(MAX.)  
 Insulation Resistance : 1000MΩ(MIN.)  
 Temperature Range : -25°C~+85°C

E2548H00-NPX-HF-NK  
 ① ② ③④⑤ ⑥

- ① Series No.
- ② H90 : Side Contact  
H00 : Up Contact
- ③ No. of Circuits
- ④ X : Product color(A--Y)  
Blank: Natural type
- ⑤ HF : Halogen Free
- ⑥ NK: No Mark  
Blank: Mark

Suitable for HLTC E2543 series terminal

Part No.	Material	Color
E2548H00-4P-HF-XX	Nylon66,UL 94V-0	白色无卤
E2548H00-4PM-HF-XX	Nylon66,UL 94V-0	米黄色无卤
E2548H00-4PA-HF-XX	Nylon66,UL 94V-0	黑色无卤
E2548H00-4PB-HF-XX	Nylon66,UL 94V-0	咖色无卤

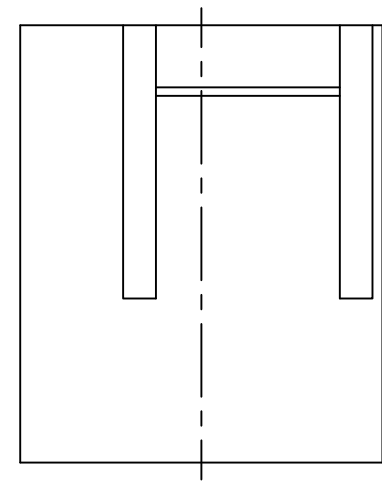
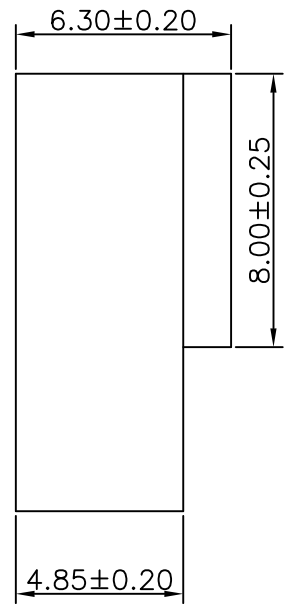
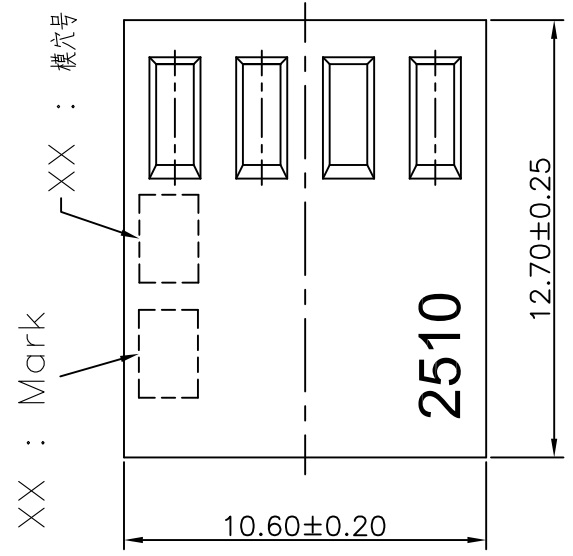
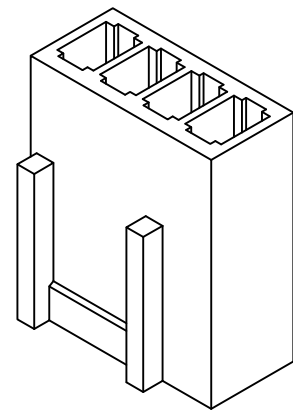
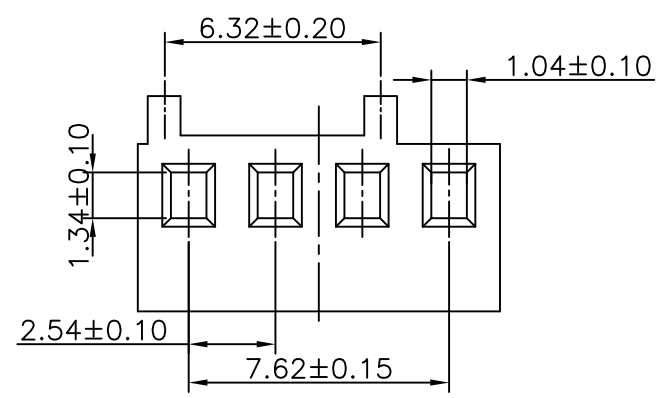

		GENERAL TOLERANCE		UNIT: mm		DATE		TITLE:		
		.X±0.30	X°±1°	DRAWN: 张自豪		2015.09.28		2510 Housing		
		.XX±0.20	.X°±	CHECKED:				VER. SCALE: N/A		
LTR NAME DATE VERISION RECORD		.XXX±0.10	.XX°±	APPROVED: 张彬彬		2015.09.28		A1 SHEET: 1/1		

东莞市宏欣蓝电子有限公司

PROJECT PART NO. E2548H00-NPX-HF-XX

DRAWING NO. E2548H

Specifications:  
 Rated Voltage : 250V AC/DC  
 Rated Current : 2.5A AC,DC  
 Withstand Voltage : 1000V AC/minute  
 Contact Resistance : 20mΩ(MAX.)  
 Insulation Resistance : 1000MΩ(MIN.)  
 Temperature Range : -25°C~+85°C  
 Suitable E2543&E2548 series Housing

E2543 I O P-XX-XX

① ②③④ ⑤ ⑥

- ① Series No.
- ② T: Terminal
- ③ 9 : Side Contact  
0 : Up Contact
- ④ P : Phosphor Bronze
- ⑤ 2E : Tin-plated
- ⑥ NK : No Mark  
Blank : Mark

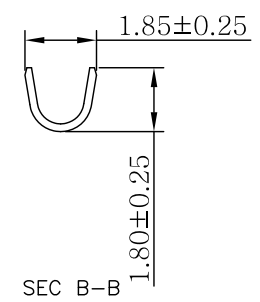
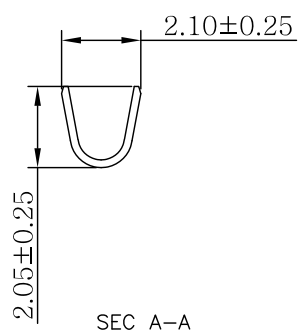
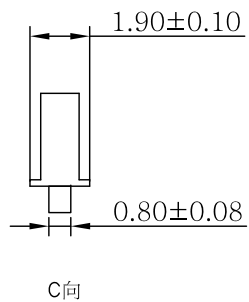
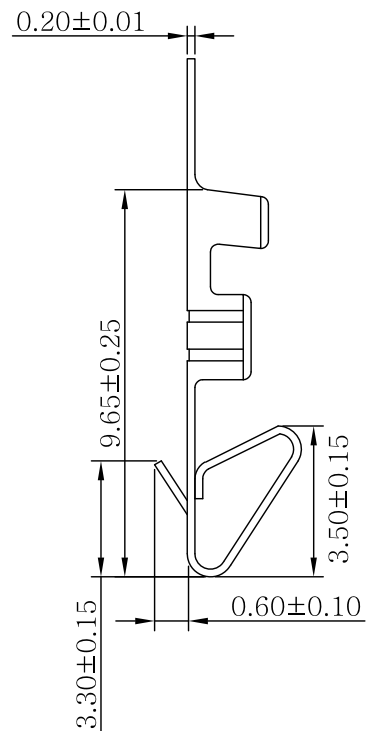
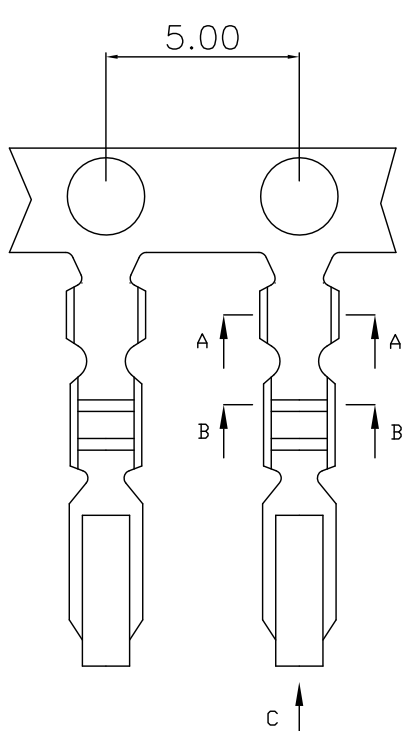

Specifications & Ordering Information:

Part No.	Material	Wire Range	Insulation O.D.	Finish	Qty/Reel
E2543TOP-2-NK	Phosphor Bronze	AWG #24~28	1.4~1.0mm	Tin-plated先镀后冲	10000PCS
E2543TOP-2E-NK	Phosphor Bronze	AWG #24~28	1.4~1.0mm	Tin-plated先冲后镀	10000PCS
E2543TOP-0A-NK	Phosphor Bronze	AWG #24~28	1.4~1.0mm	Gold-plated镀半金	10000PCS
E2543TOP-5A-NK	Phosphor Bronze	AWG #24~28	1.4~1.0mm	Gold-plated镀全金	10000PCS
E2543TOB-2-NK	Bronze	AWG #24~28	1.4~1.0mm	Tin-plated先镀后冲	10000PCS

				GENERAL TOLERANCE		UNIT: mm		DATE		TITLE: MX2510 Terminal 东莞市宏欣蓝电子有限公司 PROJECT: PART NO. E2543TOX-XX-XX DRAWING NO. E2543T		
				.X ± 0.25	X° ± 1°	DRAWN: 张自豪	2015.09.28					
				.XX ± 0.13	.X° ±	CHECKED:						
LTR NAME DATE VERISION RECORD				.XXX ± 0.08	.XX° ±	APPROVED: 张彬彬	2015.09.28	VER. A1	SCALE: N/A			

由 Autodesk 教育版产品制作

由 Autodesk 教育版产品制作